



**Weasler®**

**TORQUE LIMITER**

## F-TYPE FRICTION CLUTCH



*The FLANGE friction overrunning clutch mounts the overrunning feature to the flywheel instead of the driveshaft. This allows for a larger diameter, thinner clutch, which greatly improves heat flow from the friction surfaces to the atmosphere. Convective cooling is increased to allow the clutch to cool up to four times faster than competitive clutches. This technology dissipates heat quickly, improving durability while protecting the machine. Because the friction discs are larger in diameter, the number of friction surfaces can be reduced while improving sensitivity to wear and adjustment. The modular design offers a maximum lifted weight of 29lbs (13kg) and greatly improves ease of assembly and service.*

## PERFORMANCE BENEFITS

---

- IMPLEMENT OVERLOAD PROTECTION
- ISOLATES AND DISSIPATES HEAT MINIMIZING DOWNTIME FOR HIGHER PRODUCTIVITY
- CORROSION RESISTANT FRICTION DISCS
- OPTIMIZED DESIGN AFFORDS MORE RELIABLE TORQUE SETTING
- MINIMAL MAINTENANCE
- EASILY ADJUSTABLE TO OPTIMIZE THE CAPACITY OF THE IMPLEMENT
- MODULAR DESIGN WITH OVERRUNNING FOR HIGH INERTIA LOADS
- SMOOTH OPERATION, NO DAMAGING TORQUE SPIKES
- TORQUE TRANSMISSION WHILE SLIPPING AIDS IN DISLODGING PLUGS FOR INCREASED PRODUCTIVITY

*Quality fits. Every time.*



# Weasler®

# TORQUE LIMITER

## F-TYPE FRICTION CLUTCH

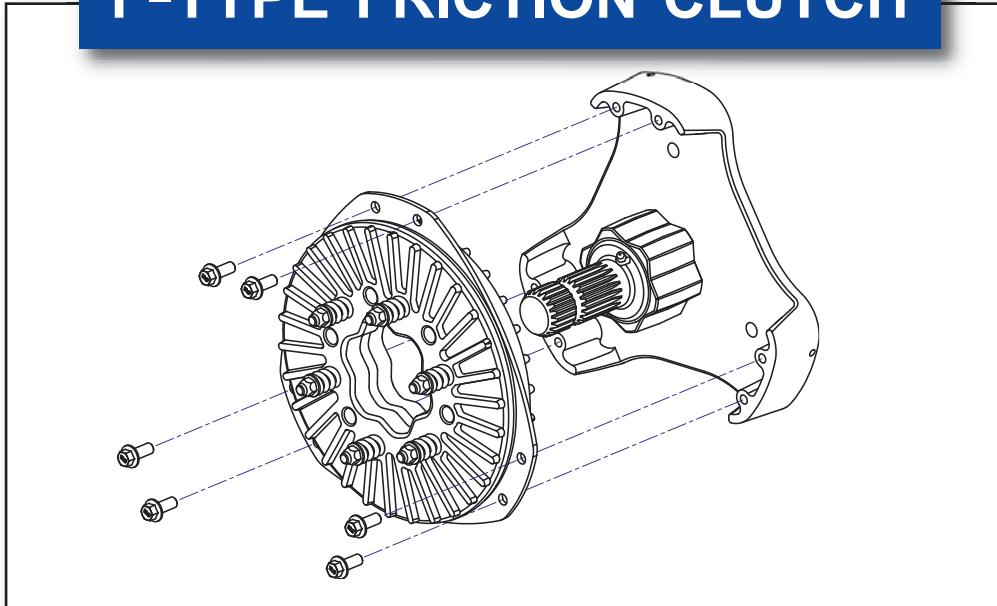

## DESIGN FEATURES

- **MODULAR CLUTCH, OFFERING A WIDE VARIETY OF FLYWHEEL AND DRIVESHAFT CONNECTIONS**
  - UNIQUE OVERRUNNING FLANGE MOUNTS TO FLYWHEEL WITH CUSTOM BOLT PATTERNS
  - FRICTION CLUTCH PACK BOLTS TO OVERRUNNING FLANGE FOR EASY SERVICE AND THERMAL ISOLATION
  - FRICTION CLUTCH PACK HAS WIDE TORQUE CAPACITY RANGE TO FIT MOST APPLICATIONS
- **GRAY IRON CLUTCH PLATES**
  - SLIP SURFACES ARE CONTROLLED TO BE AGAINST IRON FOR EFFICIENT HEAT DISSIPATION AND RELIABLE FRICTION COEFFICIENT
  - FINS ARE INCORPORATED TO QUICKLY DISSIPATE HEAT AND ISOLATE IT FROM OTHER COMPONENTS
  - LARGE FRICTION SURFACE AREA AND LOW FACE PRESSURE INCREASES WEAR LIFE
- **ADJUSTABLE COIL SPRINGS**
  - DESIGN ALLOWS THE CLUTCH FRICTION DISCS TO WEAR UNIFORMLY FOR EXTENDED LIFE
  - TORQUE PROTECTION LEVEL IS DETERMINED BY SPRING QUANTITY AND HEIGHT SELECTION AND VERIFIED FOR EACH ASSEMBLY
- **TORQUE SETTINGS AVAILABLE FROM 6000 TO 24000 in•lb (680 TO 2700 Nm)**

Weasler Engineering, Inc.  
P.O. Box 558, West Bend, WI 53095 USA  
Tel: +1-262.338.2161, Fax: +1-262.338.3709  
E-mail: [oemsales@weasler.com](mailto:oemsales@weasler.com)  
web site: [www.weasler.com](http://www.weasler.com)

Weasler Engineering BV  
P.O. Box 266, 6600 AG, Wijchen, The Netherlands  
Tel: +31 (0)24 64 89 100, Fax: +31 (0)24 64 89 109  
E-mail: [sales@weasler.nl](mailto:sales@weasler.nl)  
web site: [www.weasler.com](http://www.weasler.com)

Weasler Engineering Kft  
P.O. Box 262, H6001, Kecskemet, Hungary  
Tel: +36 (0)76 500 410, Fax: +36 (0)76 500 415  
E-mail: [sales@weasler.nl](mailto:sales@weasler.nl)  
web site: [www.weasler.com](http://www.weasler.com)