



## SERVICE INSTRUCTIONS



**BEFORE DOING ANY SERVICE OR MAINTENANCE WORK ON THE MACHINE, YOU MUST:**

- *Disengage all power*
- *Shut off the tractor engine*
- **LOOK and LISTEN!** *Make sure all moving parts are stopped.*
- *Disconnect drive shaft from tractor PTO*

Remove the drive shaft from the implement.

## INSPECTION

1. Make sure the guards rotate freely on the yokes.
2. Inspect the end yoke bores for wear and damage. Replace if necessary.
3. Pull the halves of the drive shaft apart and inspect the shafts for wear and damage. Replace if necessary.
4. Pivot the universal joints. The universal joints must rotate freely and must not be loose. If the universal joints are loose, replace them.
5. Lubricate the two halves of the drive shaft and the universal joints. Slide the two halves together.

UNCONTROLLED DOCUMENT 56-15138-03

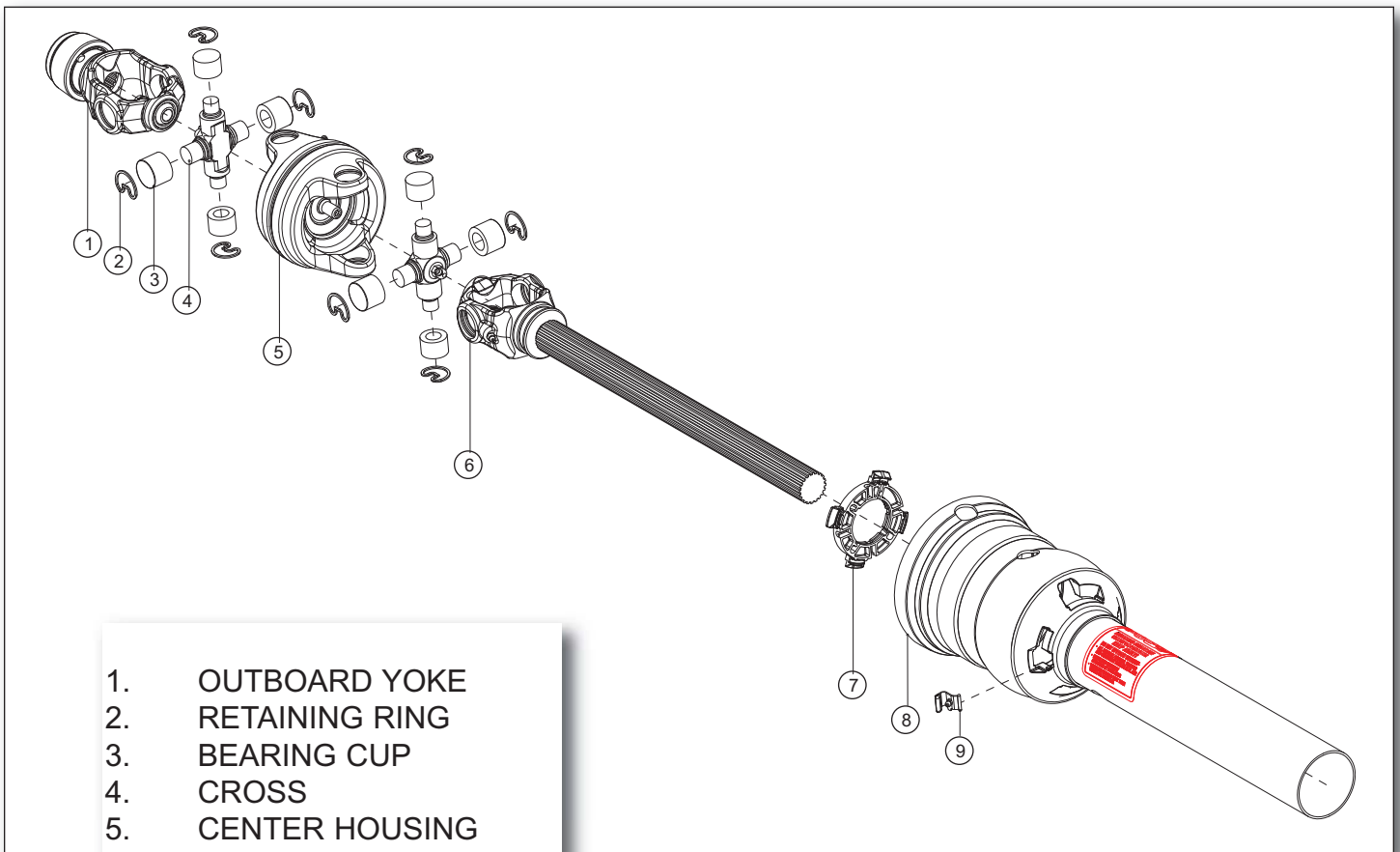

1. OUTBOARD YOKE
2. RETAINING RING
3. BEARING CUP
4. CROSS
5. CENTER HOUSING
6. YOKE AND SHAFT
7. NYLON BUSHING
8. GUARD
9. EASY LOCK CLIP



## DISASSEMBLY - CROSS & BEARING KIT

1. The drive shaft has been removed from the machine, the two halves separated, and the guards removed. Start the procedure by removing the yoke that does not have a shaft attached.
2. The bearing cups are held in the center housing by snap rings. The snap rings are on either the inner edge of the bearing cup (internal), or on the cup end (external).
  - For internal snap rings, put a shop cloth under the snap ring to catch the snap ring. Use a screwdriver and a hammer to drive the snap ring off the bearing cup (See Figure 1).
  - For external snap rings, the snap rings are against the outer end of the bearing cup. Use a hammer and a driver (that is slightly smaller than the bore) to lightly hit the snap ring (see Figures 2 & 3). This will drive the bearing cup away from the snap ring and loosen the snap ring. Remove the snap ring.
3. Set the end yoke on the vise so the ears are supported by the jaws of the vise. Hit the center housing to force the bearing cup out of the center housing (See Figure 4). The bearing cup will only be forced part way out of the center housing. **Note:** When hitting the center housing NEVER hit the machined surface of the center housing. If the machined area is damaged, the guard will not rotate freely. NEVER hit the area around the hole for the bearing cup. Distortion of the hole will make removal of the bearing cup difficult (see Fig. 4).
4. Repeat the procedure to push the other bearing cup part way out of the center housing.
5. Fasten one of the bearing cups in the vise. Make sure the jaws of the vise are as close to the center housing as possible. Hit the center housing to drive the center housing up off the bearing cup. Be careful not to hit the machined surface of the center housing (see Figure 5). Do not remove the other bearing cup from the center housing at this time.

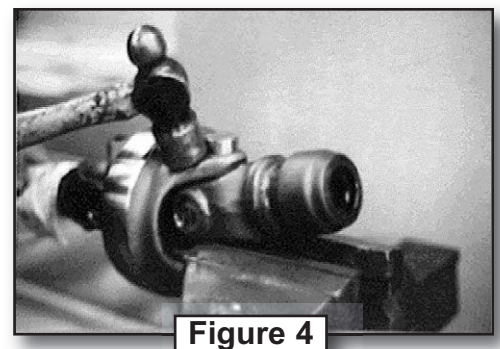
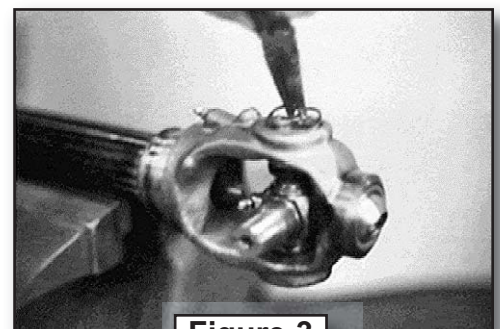
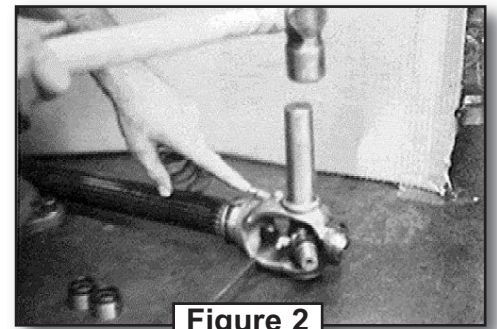
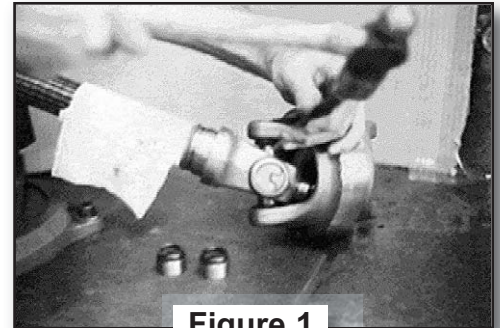



## DISASSEMBLY - CROSS & BEARING KIT...continued

6. Note the orientation of all grease fittings before removing any yokes or crosses. Remove the end yoke from the center housing.
7. Repeat steps 2 -6 to remove the shaft yoke and cross from the center housing.
8. Use the hammer and the driver to remove the two bearing cups from the center housing (see Figure 6).
9. Remove the snap rings from the end yoke and the shaft yoke (refer to Step 2).
10. Set the end yoke on the vise so the trunnions of the cross are supported by the jaws of the vise. Hit the end yoke to force the bearing cup out of the end yoke. The bearing cup will only be forced part way out of the end yoke. **Note:** When hitting the end yoke **NEVER** hit the area around the hole for the bearing cup. Distortion of the hole will make removal of the bearing cup difficult (see Figure 7).
11. Repeat Step 10 to push the other bearing cup part way out of the end yoke.
12. Fasten one of the bearing cups in the vise. Make sure the jaws of the vise are as close to the end yoke as possible. Hit the end yoke to drive the yoke up off the bearing cup, similar to Step 5.
13. Repeat Step 12 to remove the other bearing cup from the end yoke.
14. The opening between the ears on the end yoke is wider on one side. Remove the cross from the side that has the wider opening.
15. Repeat Steps 10 - 14 to remove the cross from the shaft yoke. Be careful not to hit the grease fitting in the shaft yoke.

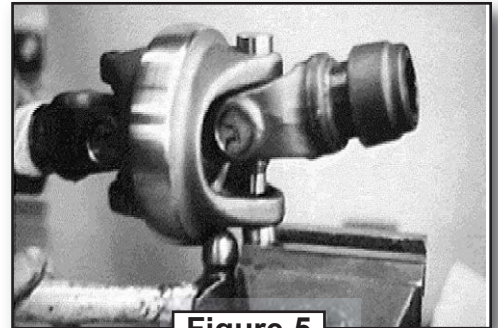

Figure 5

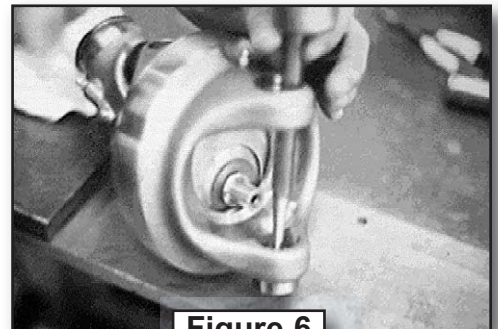

Figure 6

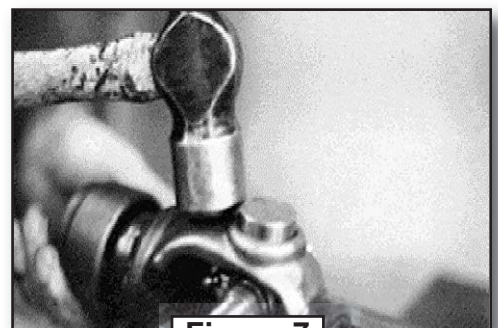

Figure 7



## INSPECTION

1. Discard the two crosses, all of the bearing cups, and all of the snap rings.
2. Clean the bores in the center housing and the yokes. Inspect the bores for damage. Replace any parts that are damaged.
3. Clean the snap ring grooves in the bores that have them. Inspect the snap ring grooves for damage. Replace any parts that are damaged.
4. Clean the trunnions of the center plate in the center housing. Make sure that none of the needles from the bearings have fallen into the center plate area of the center housing. Make sure center plate moves freely by hand.
5. Make sure the grease fitting in the center housing is clean, unobstructed, and undamaged. Replace this if necessary (see *Figure 8*).
6. Inspect the ball in the end yoke and the ball in the shaft yoke for scoring and damage. Check the end play of the balls. The end play must not be more than 0.025 in (0.635 mm). If the ball is worn, replace the yoke (see *Figure 9*).
7. Use your finger to check for grease in the ball in the end yoke and the ball in the shaft yoke. If there is no grease in the ball, the ball has not been receiving grease. Also check the ball color. If it is blue, the ball has not been receiving grease. Check the grease fitting and the grease passages in the shaft yoke (see *Figure 10*). If they cannot be cleared, replace the yoke and shaft.

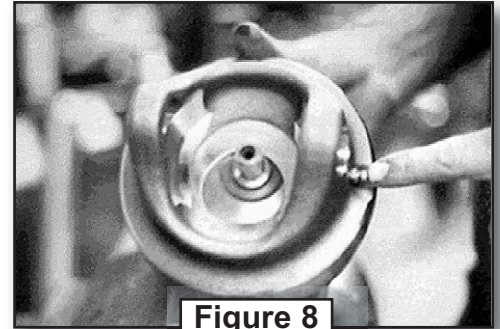

Figure 8

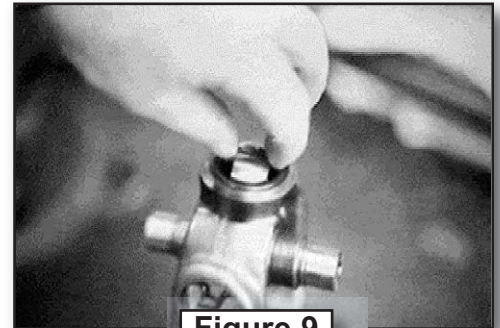

Figure 9



Figure 10



## ASSEMBLY

1. Apply grease to the bearing cup bores in the end yoke, the shaft yoke, and center housing. The grease will make the bearing cups much easier to install.
2. Install the grease fittings in the crosses. Align the grease fitting with the correct trunnions. Look at the old crosses. (See Figure 11).
3. Remove the bearing cups from the new crosses and apply grease to the needle rollers in the bearing cups. The grease is used to hold the needle rollers in the bearing cups during installation. Use your finger to push the grease into the needle rollers and to push the needles out against the bearing cup. (See Figure 12)
4. Wrap the shaft in a shop cloth to protect the splines, and mount it in the vise with the yoke up. Make sure the trunnions of the new cross are clean. Install the correct trunnions of the cross through the side of the shaft yoke that has the widest opening. The grease fitting in the cross must be away from the ball in the shaft yoke. (See Figure 13).
5. Push the cross to one side of the yoke. Use the trunnion as a pilot and push the new bearing cup onto the cross and into the opening in the ear.
6. Push the cross into the bearing cup to keep the needles in the bearing cup while driving the bearing cup. Keep the trunnions of the cross parallel with the openings for the bearing cups. Hit the bearing cup lightly with a hammer. Using the vise, drive the bearing cup into the yoke until the bearing cup is flush with the yoke.
7. Make sure the bearing cup is flat against the bench. Keep the cross in the bearing cup and start the other bearing cup into the yoke. Use a hammer to lightly drive the bearing cup into the yoke just far enough to make sure the bearing cup is straight. If the grease fitting in the yoke is down, support the yoke on a block to prevent damage to the grease fitting.

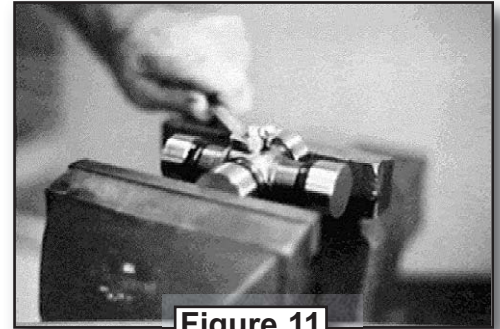

Figure 11

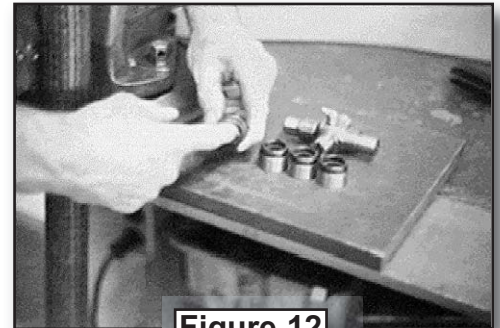

Figure 12

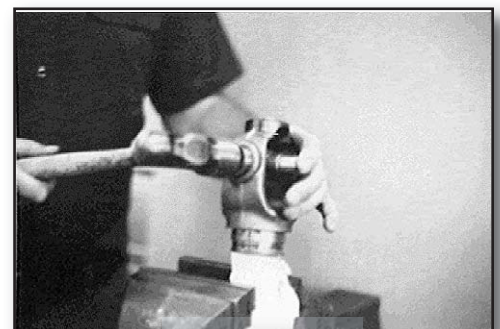

Figure 13



## ASSEMBLY...continued

8. Put the shaft yoke into the vise so the bearing cups are square with the jaws of the vise. Make sure the trunnion is aligned with the bearing cups. Tighten the vise until both bearing cups are flush with the yoke (see *Figure 14*).
9. Using the large driver used in disassembly, drive one of the bearing cups into the yoke until the groove for the snap ring can be seen. Make sure the ear of the yoke is flat against the bench. If the grease fitting in the yoke is down, support the yoke on a block to prevent damage to the grease fitting.
10. Make sure the groove for the snap ring is clean. Install the snap ring. Use a screwdriver to push the snap ring into the groove all the way around.
11. Set the shaft yoke on the vise so the shoulders of the cross are supported by the jaws of the vise. **DO NOT** allow the machined surfaces to contact the vise. Hit the yoke with the hammer to seat the bearing cup against the snap ring. **DO NOT** hit the yoke near the opening for the bearing cups (see *Figure 15*).
12. Repeat steps 9 - 11 for the other snap ring.
13. Repeat steps 1 - 12 for the end yoke.
14. Wrap a shop cloth around the shaft to protect the splines. Clamp the shaft in the vise so the shaft yoke is up. The ball in the shaft yoke has a flat area around each end of the hole. The flat area is wider on one side of the ball (see *Figure 16*). Rotate the ball so the wider flat area is up.
15. Rotate the center housing so the grease fitting is away from the shaft yoke. This will align the grease fitting in the center housing with the hole in the guards. The grease fittings in the center housing and the cross must be toward the same side of the assembly. Make sure the pin of the center plate in the center housing is clean. Install the pin in the ball and cross in the ears of the center housing (see *Figure 17*).
16. Make sure there is grease in the holes for the bearing cups in the center housing. Push the cross to one side of the yoke.

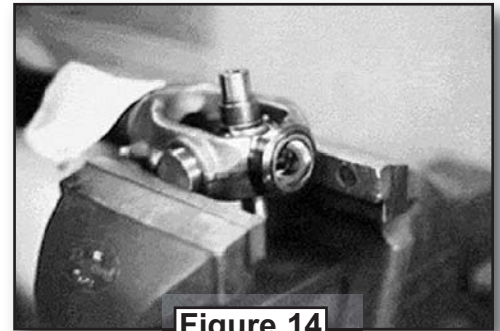

Figure 14

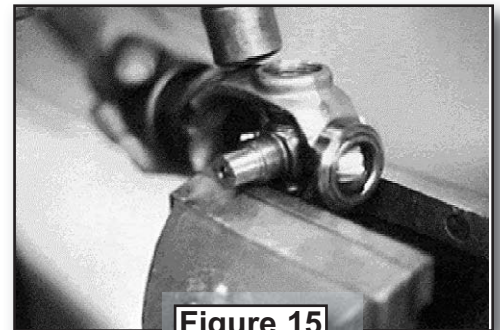

Figure 15

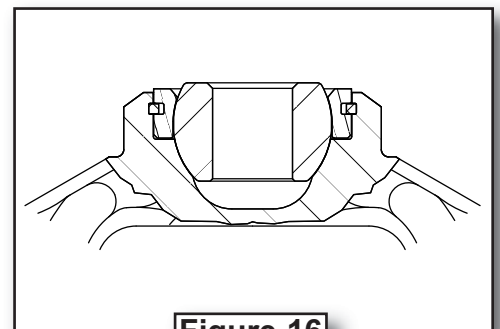

Figure 16

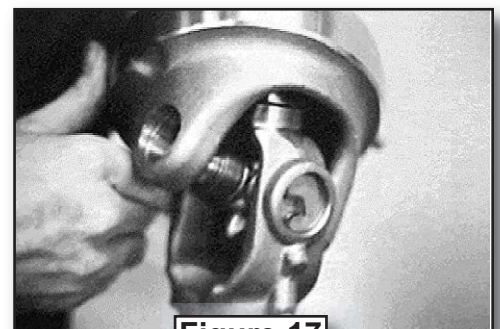

Figure 17



## ASSEMBLY...continued

17. Use the cross trunnion as a pilot. Start the new bearing cup on the cross and into the opening in the center housing. Push the cross into the bearing cup while driving the trunnions of the cross parallel with the openings for the bearing cups. Hit the bearing cup lightly with a hammer. Using the vise, drive the bearing cup into the yoke until the bearing cup is flush with the yoke ear (see *Figure 18*).
18. Keep the cross in the bearing cup and start the other bearing cup into the center housing. Use a hammer to drive the bearing cup into the yoke just far enough to make sure the bearing cup is straight.
19. Put the center housing into the vise so the bearing cups are square with the jaws of the vise. Make sure the trunnions are aligned with the bearing cups. Tighten the vise until both bearing cups are flush with the ears. Make sure the needle rollers do not fall out of the bearing cups (see *Figure 19*).
20. Using the driver and hammer, drive one of the bearing cups into the center housing until the groove for the snap ring can be seen on the bearing cup.
21. Install the snap ring. Make sure the snap ring is seated in the groove all the way around.
22. Repeat steps 20 - 21 for the other snap ring.
23. Set the shaft yoke on the vise so the ears of the shaft yoke are supported by the jaws of the vise. Carefully hit the center housing with the hammer to seat the bearing cup against the snap ring. **DO NOT** hit the center housing on the machined surface or near the opening for the bearing cup (see *Figure 20*).
24. Turn the shaft yoke over in the vise. Carefully hit the center housing with the hammer to seat the other bearing cup against the snap ring.
25. Repeat steps 14 - 24 for the end yoke (see *Figure 21*).
26. Apply grease to the fittings in the crosses until grease comes from the seals. Apply ten pumps to the fitting on the shaft yoke supplying the ball sockets. Apply ten pumps to the fitting on the center housing, supplying the center plates.
27. Clean the shaft and sleeve splines, and grease them.

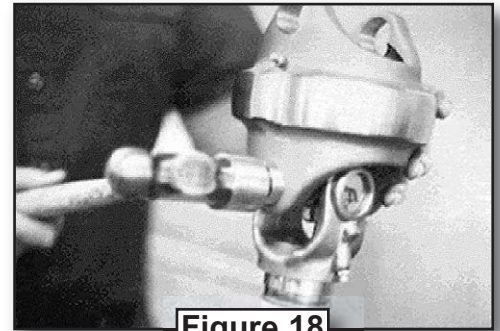

Figure 18

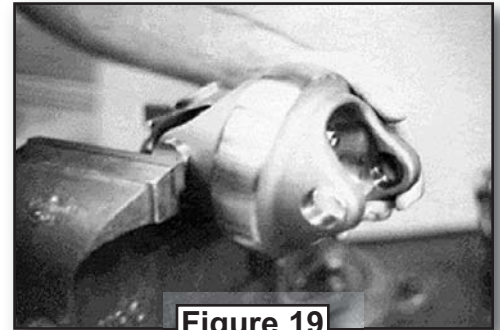

Figure 19

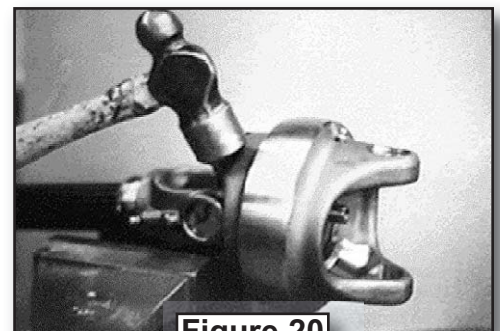

Figure 20

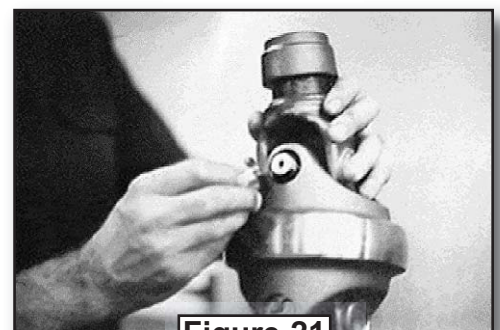

Figure 21